

1

2

3

4

5

6

7

8

9

10

11

12

13

14

15

16

17

I

J

17

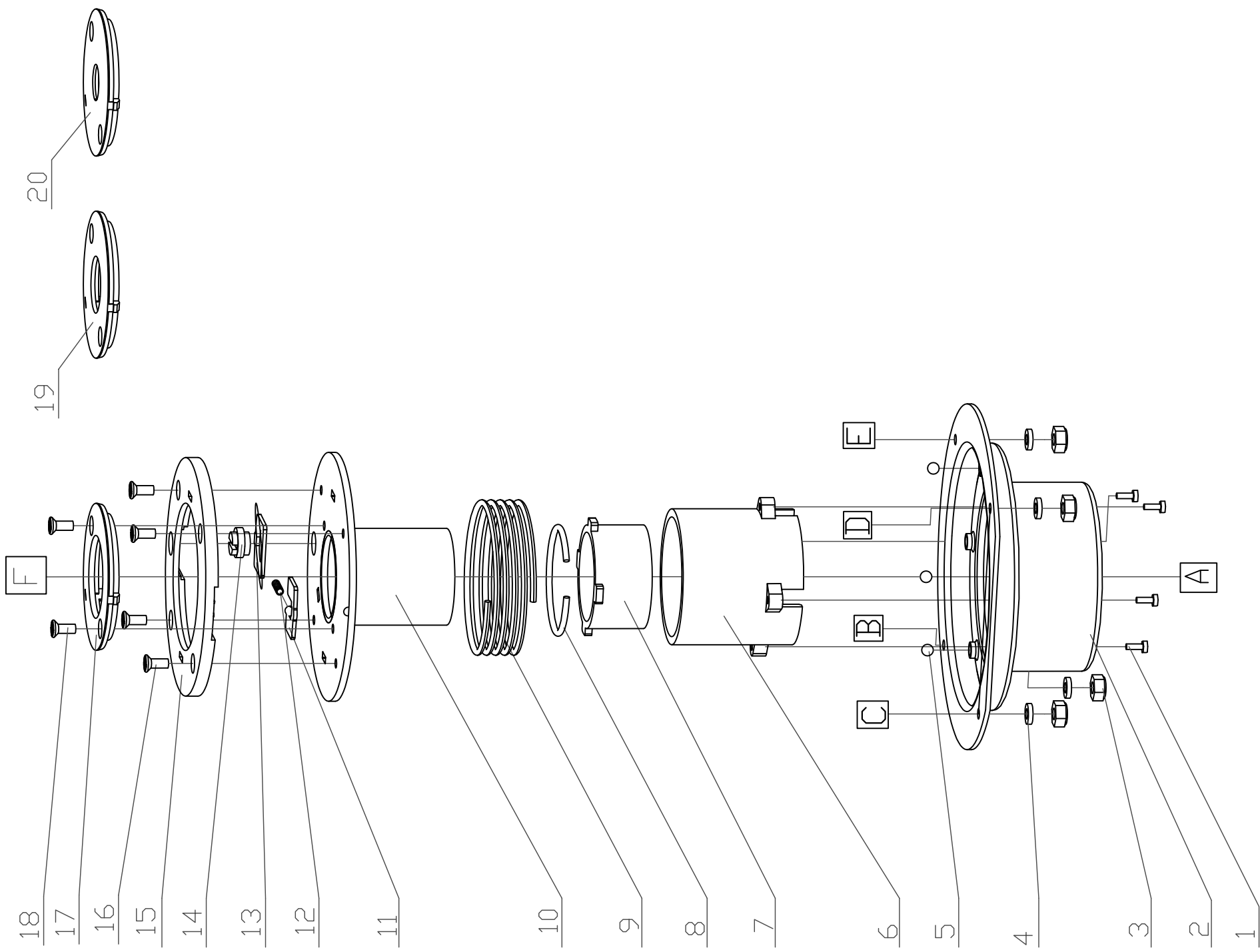

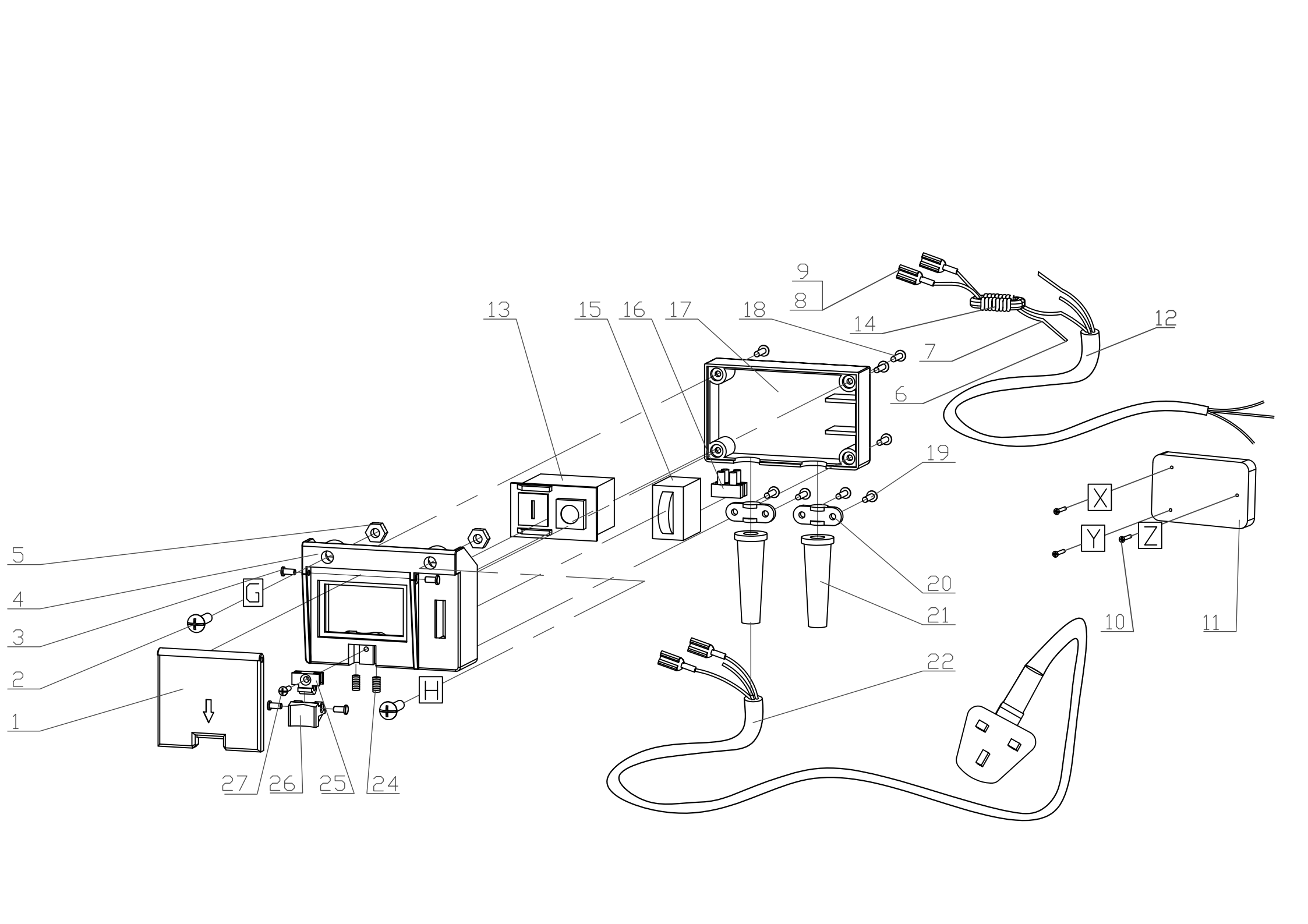

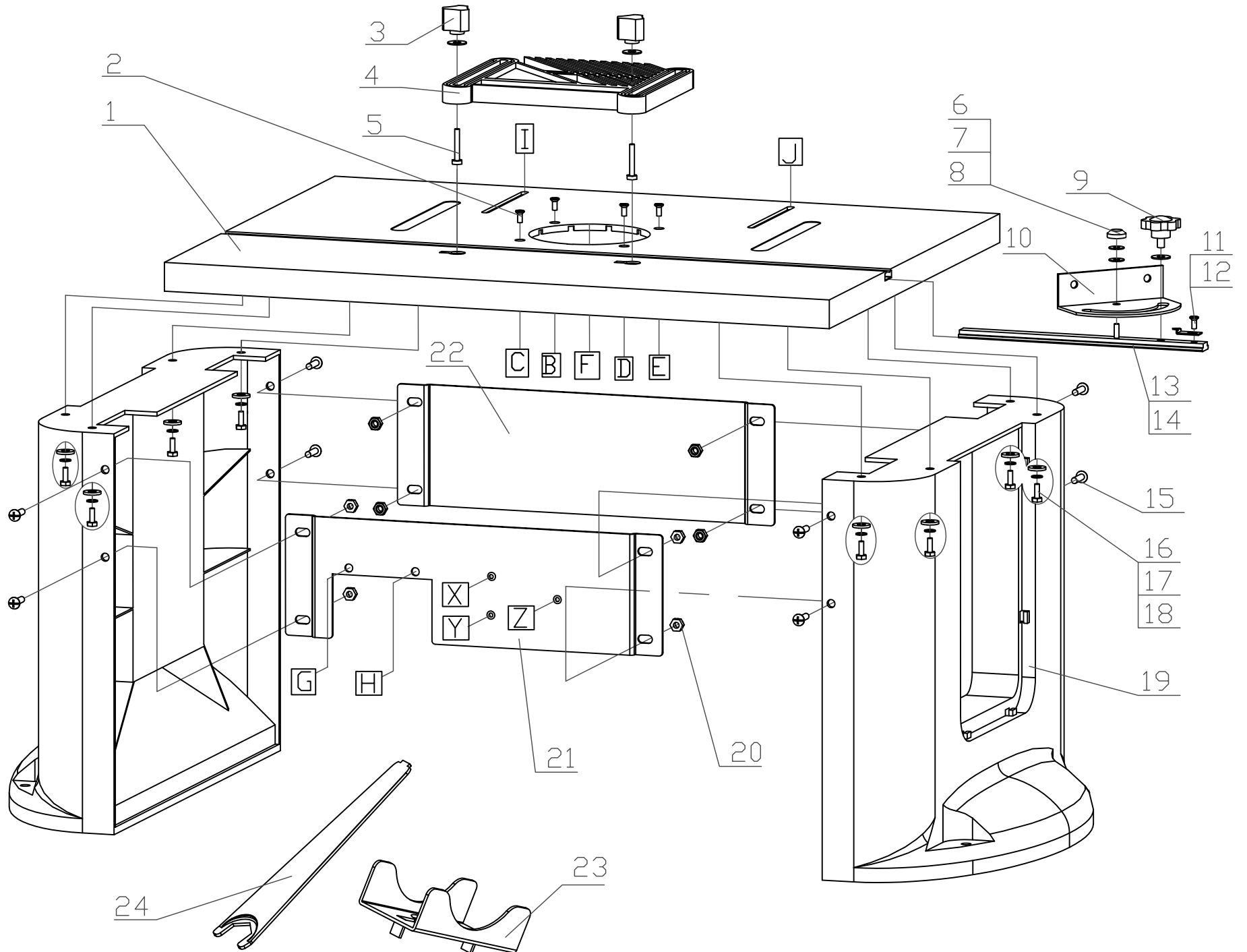

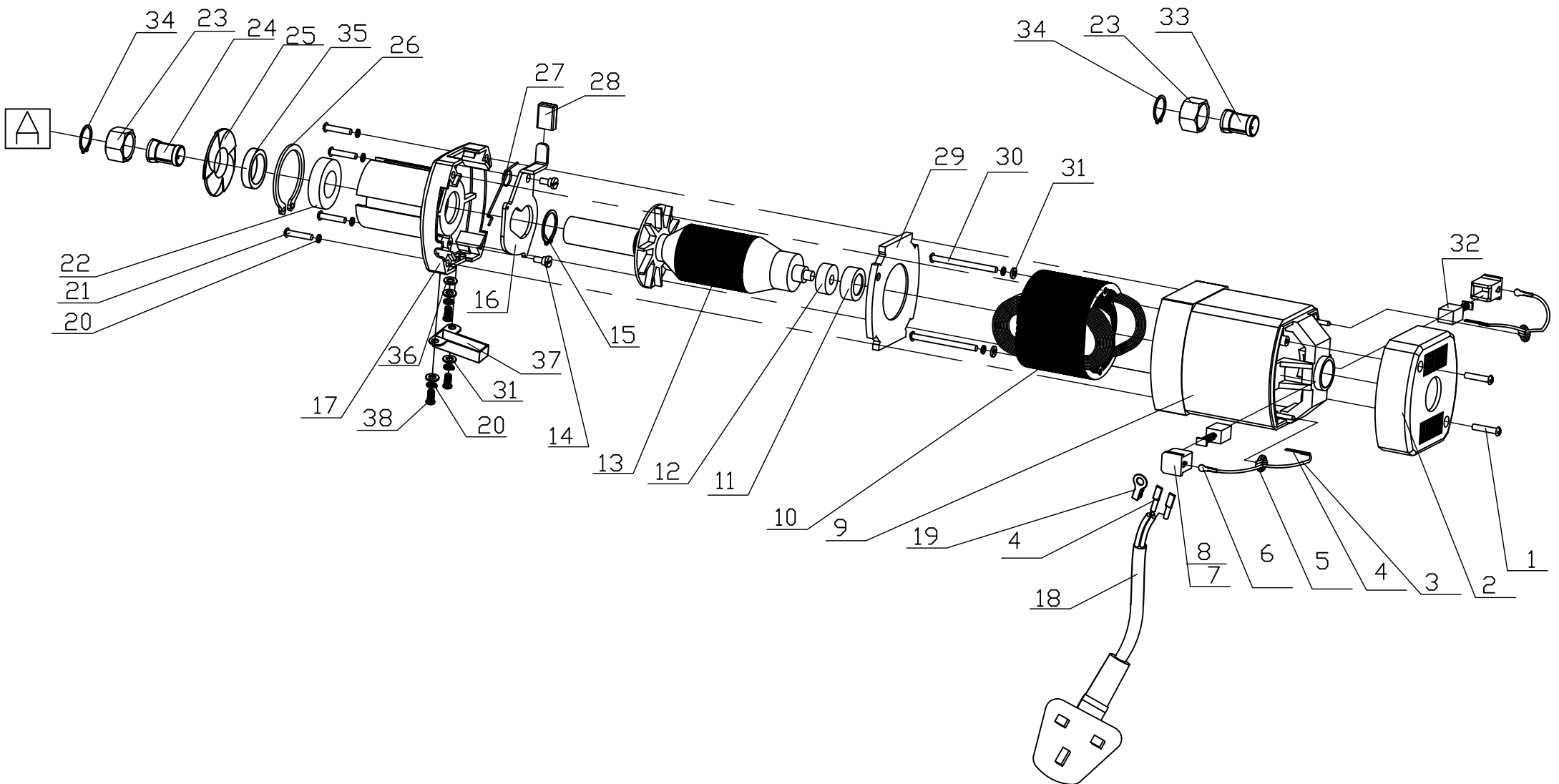

bs 50

Höhenverstellung



Skizze	Art.Nr.	Benennung
015	390 2101 022	Abdeckscheibe
017	390 2101 024	Abdeckscheibe Ø 35,8
019	390 2101 025	Abdeckscheibe Ø 21,6
020	390 2101 026	Abdeckscheibe Ø 13,7
026	390 2101 037	Distanzring

Fräsanschlag

Skizze	Art.Nr.	Benennung
006	390 2101 020	Schutzgehäuse
013	390 2101 021	Flügelmutter M6
17	390 2101 029	Andrückschieber
7,8,11	390 2101 036	Anschraubbolzen
o.Abb.	390 2101 033	Absaugstutzen

Schalter

Skizze	Art.Nr.	Benennung
013	390 2101 011	Schalter
015	390 2101 028	Drehzahlregler
001 - 027	390 2101 035	Bedienkonsole kpl.

Gestell

Skizze	Art.Nr.	Benennung
4	390 2101 029	Andrückschieber
010	390 2101 023	Schwenksegment
024	390 2101 032	Schlüssel
023	390 2101 034	Gegenhalter

Motor

Skizze	Art.Nr.	Benennung
	390210 1010	Motor
7, 8	390210 1031	Bürstenhalter
024	390210 1027	Spannhülse 8mm
032	390210 1030	Kohlebürsten Satz = 2 Stück